

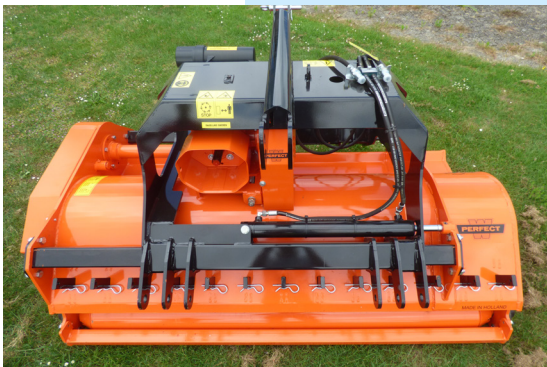

VARIOCHOP

**UNIVERSAL
FLAIL
CHOPPERS**

VARIOCHOP



540 / 750 / 1000 RPM DRIVE IN ONE MACHINE

The heavily constructed flail chopper series VARIOCHOP have especially been designed for use by customers disposing of different tractors to drive.

A special headstock allows for use as front and as rear mounted models without any transformation.
A gearbox with integrated overrunning clutch that accepts any direction of rotation
For use with 540, 750 or 1000 rpm by means of simply repositioning the pulleys

**Universal shredder for use with all tractors.
No matter brand or model.**



VARIOCHOP

Universal flail choppers

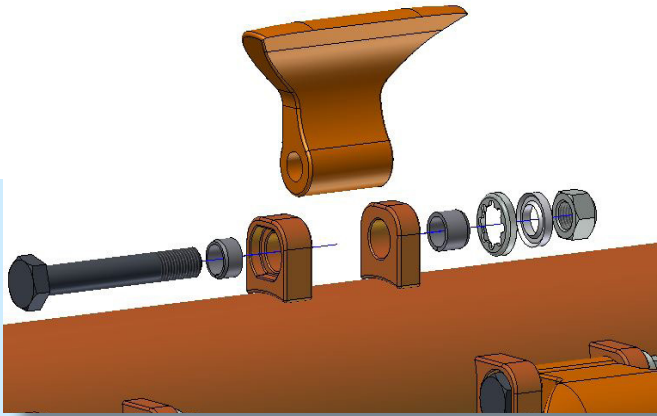

2,2 kg (5 lbs) heavy-duty "PERFECT" flails are especially designed for pulverizing prunings. They are fitted to the double electronically balanced flail rotor with heavy bolts and replaceable steel bushings. They provide an excellent pulverization. Combi-flail are optionally available.



The gearbox with spiral toothed gears and the V-belts with partially springloaded automatic belt tensioner assure an indirect flexible drive with maximum security and minimum maintenance.

Change of rpm by simply repositioning the pulleys.

HYDRAULIC OFFSET & COMBI FLAILS

The standard configuration includes a hydraulic offset feature (except model 135 cm).

Extra heavy (2,7 kg) Combi-flails with a replaceable chopper blade out of special steel. High impact and continuously sharp cutting edge. Optional available.

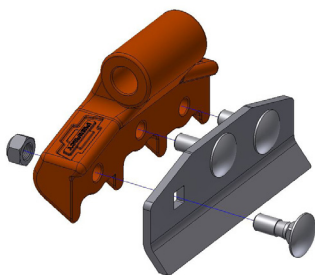

EXTRA'S

- Rear rake tines
- Combi-flails
- Pro-fix protection against stones
- Wearing plate

Technical specifications	VARIOCHOP-135	VARIOCHOP-150	VARIOCHOP-180	VARIOCHOP-210
Cutting width (cm/ inch)	135/ 4'5"	150/ 4'11"	180/ 5'11"	210/ 6'11"
PTO speed (rpm)	540	540	540	540
Min. power* required at 540 rpm (kW/ HP)	18/ 25	21/ 28	25/34	30/ 41
Flails 2,2 kg = 5 lb/ Combi-flails 2,7 kg = 6 lb	8	9	12	12
Total width (cm/ inch)	157/ 5'2"	172/ 5'7"	202/ 6'8"	232/ 7'8"
Tractor 3 pt. linkage (cat.)	I + II	I + II	I + II	I + II
Maximum offset from tractor centre (cm/ inch)	-	99/3'3"	129/4'3"	159/5'3"
Weight (kg/ lb)	660/ 1455	700/ 1543	740/ 1631	810/ 1786
Number of rake tines, option	9	11	13	15

As our policy is one of continuous improvement, we reserve the right to change the specification or to modify the desing without prior notice



Van Wamel B.V.

📍 **Van Wamel B.V.**
Energieweg 1, 6658 AE
Beneden Leeuwen
The Netherlands

☎ +31 (0) 487 59 29 44
☎ +31 (0) 487 59 29 44
🌐 www.vanwamel.nl
@ perfect@vanwamel.nl

Your **PERFECT** dealer